

TASC

THE AUTOMATED SHOP CONFERENCE

OCTOBER 10-11, 2023

SUBURBAN COLLECTION SHOWPLACE | NOVI, MI

Usher in the Age of Automation

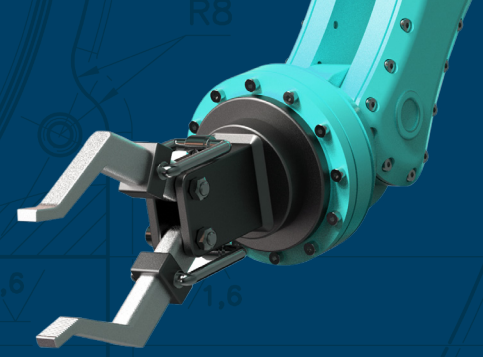

Conference program
curated by:



Brent Donaldson
Editor-in-Chief
Conference Programming
Co-Chair



Matt Kirchner
President
Conference Programming
Co-Chair

POWERED BY



PRODUCTION
Machining

MoldMaking
TECHNOLOGY.



MONDAY, OCTOBER 9, 2023

12:00 p.m. Facilities Tour of FANUC and Lift *(optional)*
1:00 – 5:00 p.m. Registration Open
6:00 – 8:00 p.m. Opening Cocktail Party

TUESDAY, OCTOBER 10, 2023

7:30 - 8:30 a.m. Registration Open / Breakfast

AUTOMATION TECH FOR MACHINING

8:30 - 9:00 a.m.	OPENING KEYNOTE Culture Changeover – Preparing Your Team for Automation Matt Kirchner LAB Midwest
9:00 - 9:30 a.m.	Manufacturing Applications Coordinator Brad Cisewski Pointe Precision
9:30 - 10:00 a.m.	Machine Tool Automation and Process Considerations Michael Lail Okuma America
10:00 - 10:30 a.m.	NETWORKING BREAK
10:30 - 11:00 a.m.	Smart Technology Systems: Automating Each Step of the Manufacturing Process Rob Caron Caron Engineering, Inc.
11:00 - 11:30 a.m.	Automated Digital Inspection Craig Mathews ThyssenKrupp Bilstein of America
11:30 a.m. - 12:00 p.m.	Total Process Control for CNC Machines and Robots Denis Vasilescu Renishaw, Inc.

12:00 - 1:00 p.m. **LUNCH**

MACHINING PROCESS AUTOMATION

1:00 - 1:30 p.m.	Does the Idea of Investing in a Flexible Automation System Give You Butterflies? Success Stories and Sound Advice for Shops of All Sizes Christopher Rezny Fastems Group
1:30 - 2:00 p.m.	Robots on the Shop Floor – a Practical Introduction Andra Keay AMT
2:00 - 2:30 p.m.	From Manual to Automated: Developing a Low-Cost Machine Tending System for Independent Machine Shops Mike Becker Harland Sharp
2:30 - 3:00 p.m.	Small Shop, Big Gains: Transforming Job Shops with Simple Cobot Machine Tending Jake Beahan Productive Robots

3:00 - 3:30 p.m. **NETWORKING BREAK**

JUSTIFYING AUTOMATION WITH ROI

3:30 - 4:00 p.m.	Adapt Your Manufacturing Process: Do MORE with LESS Steve Alexander Acieta
4:00 - 4:30 p.m.	Keep Your Lights ON by Going Lights OUT: How Lights Out Manufacturing Can Make You Money Jacob Sanchez Industrial Strength Marketing
4:30 - 5:00 p.m.	The Hidden Factors in Calculating a Robot's ROI Steve Alexander Acieta

5:00 - 6:30 p.m. **NETWORKING RECEPTION**

WEDNESDAY, OCTOBER 11, 2023

8:00 - 9:00 a.m. Registration Open / Breakfast

ROBOTS, LABOR & TECHNOLOGY

9:00 - 9:30 a.m.	I Thought Robots Were Supposed to Make Everything Easier!?! Nathan Byrman Wolfram Manufacturing
9:30 - 10:00 a.m.	Robots: Your Key to Employee Retention Robby Komijencovic Acieta
10:00 - 10:30 a.m.	Smart Robotic Cells: Labor Shortage Solutions for Surface Finishing Applications Eric Summa GreyMatter Robotics

10:30 - 11:00 a.m. **NETWORKING BREAK**

SOLVING FOR AUTOMATION TALENT

11:00 - 11:30 a.m.	The 5 Steps to Upskilling Your Workforce in the Age of Industry 4.0 Ivan Manuel LAB Midwest
11:30 a.m. - 12:00 p.m.	World Class Talent Pipeline: Partnering with Your Technical/Community College to Secure Automation Talent Nick Mootz ATS Midwest

12:00 - 1:00 p.m. **LUNCH**

COBOTS & MACHINING

1:00 - 1:30 p.m.	Automated Inspections with Cobots Fabian Schmahl Bold Promises Delivered
1:30 - 2:00 p.m.	Industry 4.0 for Me - Workers Alongside Automation Dan Bagley Strategic Ink - SideKick Werks
2:00 - 2:30 p.m.	Think Long Term Success: Why Cobots are the First Choice for Many Small to Medium-sized Companies Jerry Perez FANUC America Corporation
2:30 - 3:00 p.m.	Win More Business, Boost Productivity and Improve Retention in Your Shop with Collaborative Automation Will Healy III Universal Robots

3:00 p.m. **END OF CONFERENCE**

Register and learn more at
TASCevent.com

